

LET THERE BE LIGHT • Speed and agility • INNOVATOR OF THE YEAR  
• Welcome to the jungle • CHILD'S PLAY CREATES JOBS • Back in  
the saddle • INNOVATIVE RAW MATERIALS • Green fire suppressant

# MEET #1-2015 SANDVIK

SANDVIK GROUP MAGAZINE



ENERGY  
EFFICIENCY  
A SUSTAINABLE  
CONTRIBUTION

How can energy-intensive  
companies make a positive  
contribution? PAGE 10.

**SPEED AND AGILITY**

**USA** Meet the new Sandvik Venture President Jim Nixon. **PAGE 8.**

**LET THERE BE LIGHT**

**NORWAY** The big picture underground. **PAGE 4.**

**VERSATILE SCREEN**

**CHINA** A new screen was introduced at the Bauma trade fair. **PAGE 9.**

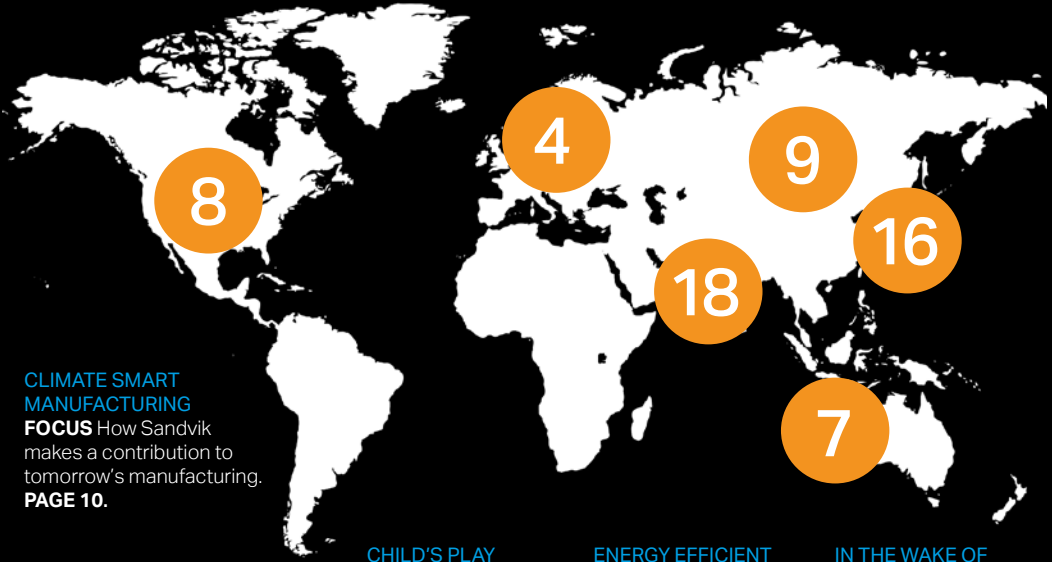

**CLIMATE SMART MANUFACTURING**

**FOCUS** How Sandvik makes a contribution to tomorrow's manufacturing. **PAGE 10.**

**CHILD'S PLAY CREATES JOBS**

**INDIA** Bringing the children to the office. **PAGE 18.**

**ENERGY EFFICIENT MINING TRUCK**

**AUSTRALIA** Saving energy with innovative truck. **PAGE 7.**

**IN THE WAKE OF A TSUNAMI**

**JAPAN** Energy solutions after the 2011 disaster. **PAGE 16.**

# CONTENT #1-2015



Follow us in social media and find more stories at: [sandvik.com/sandvikstories](http://sandvik.com/sandvikstories)



**MEET SANDVIK:** The Sandvik Group magazine

**PUBLISHER RESPONSIBLE UNDER SWEDISH PRESS LAW:** Pär Altan

**EDITOR-IN-CHIEF:** Maline Knutsen **PRODUCTION:** Spoon Publishing AB

**ART DIRECTOR:** Eva Englund **PRINT:** Falk Graphic **DATE OF PRINT:** March 2015

Published in Swedish and English, in printed form and at [www.sandvik.com](http://www.sandvik.com) **EMAIL:** [info.group@sandvik.com](mailto:info.group@sandvik.com)



## LEADING THE WAY FORWARD

**MOST PEOPLE AGREE** that the world must develop toward a sustainable energy future. Across all businesses, companies are looking for ways to reduce their energy consumption. We at Sandvik are partnering with our customers to achieve a higher energy-efficiency gain. With our long history of developing leading technologies, products and solutions we are contributing to the progress toward energy sustainability. We are prepared to meet our customers' requirements for energy-efficient solutions. In this issue you can read more about our energy-efficient products and solutions on page 10.

Creating value in all areas is key for us. On January 1, 2015, I welcomed Jim Nixon as President of Sandvik Venture and member of our Group Executive Management team. He was previously President of Varel International Energy Services, which Sandvik acquired in 2014. Jim Nixon brings with him exceptional knowledge and experience in the energy sector as well as confidence in the future. Currently we are facing uncertainty in the energy segment, but our long-term strategy to further grow our position in the energy field remains. On page 8 Nixon shares his views on the competitive landscape in these markets.

**IT WAS VERY INSPIRING** to participate in the World Economic Forum's Annual Meeting along with world leaders from across business, governments and academia, as well as other leaders of society, to discuss our ever-changing world. I left with strong impressions and more than one glimpse of what the future might look like, as well as with facts and inspiration on how to steer Sandvik through that future.

We have started off 2015 with confidence, after a stable full-year result with many great achievements from all of us within Sandvik. With this as a base we are well positioned for the journey ahead, building an even stronger Sandvik.

Finally, I'm proud to share this issue with you. It has a new look and feel, reflecting our strengthened brand identity as a leading high-tech and global engineering group with a strong focus on customers and shareholders. I hope you feel this mirrors the progress of our company. It's great to be a part of it!

*Olof Faxander, President and CEO, Sandvik AB*



# LET THERE BE LIGHT

Norway's extreme coastal topography, characterized by high mountains and deep fjords, poses a challenge for the country's Highways Authority, responsible for creating its transportation infrastructure.

The spectacular Lærdal tunnel (pictured) opened in 2000. At 24,510 meters it is the world's longest road tunnel. It will soon be joined in the record books by the Solbakk tunnel, in Norway, which will be the world's longest subsea road tunnel, scheduled to open 2017. Two three-boom electro-hydraulic drilling jumbos under the trademark Sandvik DT1131i and two two-boom electro-hydraulic jumbos, under the trademark DT921i, will be used to excavate the tunnel. ■



See more tunneling  
images taken by Muzaffer  
Bayazitoglu, Sandvik  
Turkey, February 2015, at:  
[instagram.com/sandvikgroup](https://www.instagram.com/sandvikgroup)

PHOTO: SVEIN-MAGNE TUNLI

# NEWS



## DIVERSITY AWARD

– Olof Faxander, President and CEO, Sandvik, has been nominated to the prestigious Diversity Award – “CEO driving Diversity” – run by Sweden’s leading Management Magazine Manager. Read the full story on [sandvik.com](http://sandvik.com)

# 32

– number of pages in the new Meet Sandvik magazine you are holding in your hand.

**AKTIV GROTESK** – name of the magazine’s new type face. **165 X 239** – millimetres is the size of the new magazine. **ORANGE** – new color highlight together with Sandvik blue.

**ILLUSTRATIONS** – A new way of creating illustrations has been developed, as seen on page 7.



## SANDVIK LAUNCHES GREEN FIRE SUPPRESSANT

Unlike conventional fire suppressant foams that can remain in the environment for thousands of years after discharge, Sandvik Fire Suppression’s launch of Eclipse, the world’s first fluorine-free fire suppression foam for mobile equipment that rapidly biodegrades. “The foam is superior to fluorine-based foams with faster knockdown while still maintaining post-fire protection – making it more efficient at putting out fires,” says Michael Sargaison, Sandvik Fire Suppression.

## RAW MATERIALS INNOVATIONS

**SANDVIK IS ONE** of the 100-plus leading companies and research and academic institutions that have partnered up to create sustainable growth from raw materials innovations. Finding replacements to current critical elements in hard materials production is a key driver for the company.

“To give an example of the benefits from this initiative we can develop more automated mining in extreme conditions which will enable our customers to source sustainable raw materials. We can also form cost efficient substitution and recycling processes and pioneering solutions fit for their future needs”, says Anna Hultin Stigenberg, Principal R&D Expert in Sandvik Coromant and Chair of the International Steering Committee KIC Raw Materials.



Automated mining allows for sourcing of raw materials in extreme conditions.



**“We have chosen to participate in the Swedish Leadership for Sustainable Development’s work on anticorruption, since we see this as a common challenge across industries.”**

Sandvik President and CEO Olof Faxander spoke at the World Economic Forum Annual Meeting 2015.

# ENERGY-EFFICIENT MINING TRUCK

**IN AUSTRALIA, SANDVIK LISTENED TO ITS CUSTOMERS** and built a mining truck with a strong focus on customer requirements. The truck, launched as TH663, has an ISO certified ROPS/FOPS cabin with air conditioning and a dump box that can handle 36 m<sup>3</sup>, or 63 000 kg, of material. It is about eight tons lighter than the previous generation and features efficient diesel consumption. According to customers, this has yielded significant cost savings. An example of how Sandvik listens to its customers is TH663, currently only sold in Australia, but with a strong focus on customer requirements.

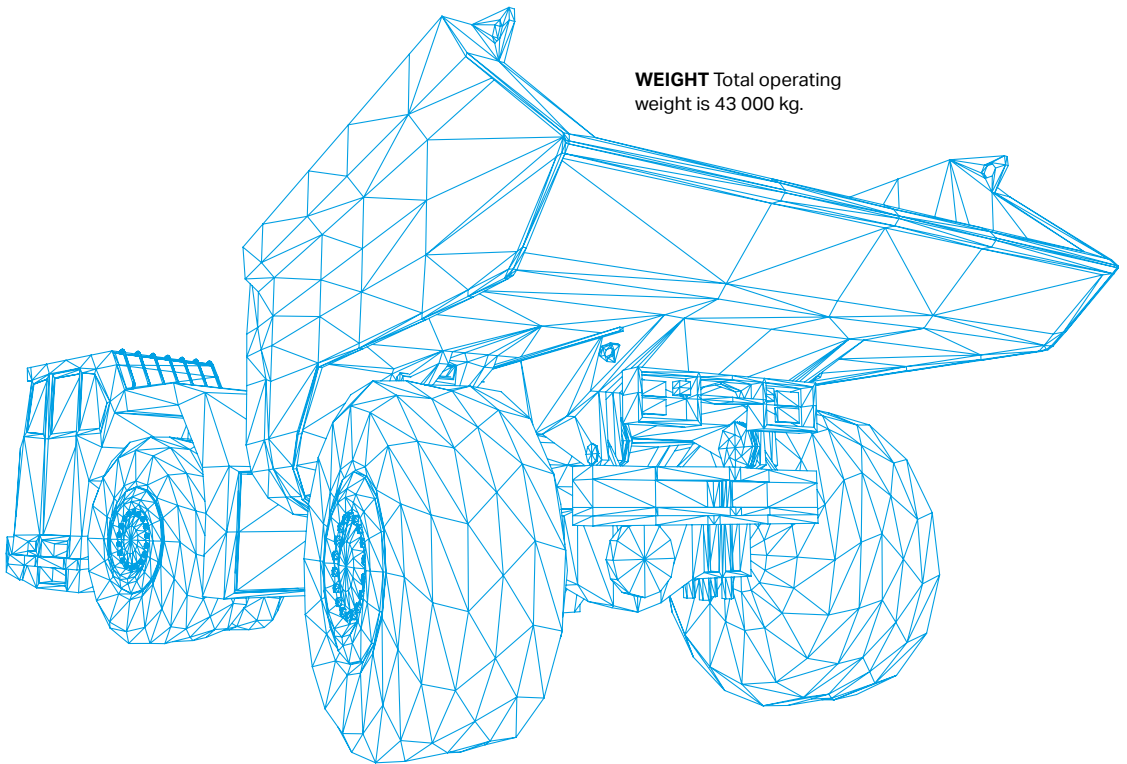

**WEIGHT** Total operating weight is 43 000 kg.

#### **MAIN DIMENSIONS**

Total length 11 580 mm, maximum width and height 3 480 mm.

#### **ENGINE** Diesel engine

Cummins QSK with an output of 567 kW (760 hp).

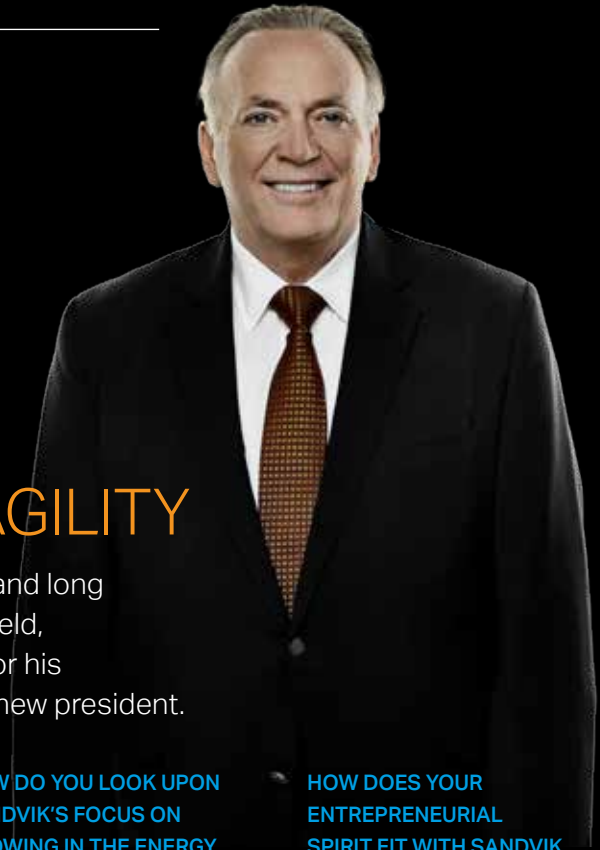

## SPEED AND AGILITY

With his entrepreneurial spirit and long experience in the oil and gas field, Jim Nixon is a perfect match for his position as Sandvik Venture's new president.

### TELL US ABOUT YOUR BACKGROUND WITHIN OIL AND GAS.

My background is in mechanical and production engineering, which took me offshore in the North Sea for the first time in 1978. Working as a service and commissioning engineer was my introduction to the upstream oil and gas market and operations. This experience got me interested in the downhole drilling environment and moved my career into the well construction environment. I have been in sales management in the North Sea, in operations and general management for global oil and gas service companies and senior vice president at a publicly traded oil service corporation. I led the management buy-in at Varel in 1998.

### HOW DO YOU LOOK UPON SANDVIK'S FOCUS ON GROWING IN THE ENERGY SEGMENT?

Energy, including oil and gas, is forecast long-term to be a business segment that will deliver higher-than-average growth opportunities. With the focus on energy and energy efficiency within Sandvik Materials Technology and a platform in oil and gas services within Sandvik Venture, complemented by offerings from the other business areas, Sandvik now has what we need to become a very significant player in this attractive market segment.

### HOW DOES YOUR ENTREPRENEURIAL SPIRIT FIT WITH SANDVIK VENTURE'S FOCUS ON ACCELERATING GROWTH?

I see Sandvik Venture as a very entrepreneurial business area. We are in competitive markets that require speed and agility to be best at delivering solutions to customer needs. In line with Sandvik Venture's mission, I believe that smaller, faster-growing product areas need to be managed somewhat differently than the larger, more-established businesses, which we can do in our setup. ■

---

**"Sandvik now has what we need to become a very significant player in this attractive market segment."**



NO.1

**Ranking for sandvik.com** in the category "Best Corporate Website" in the recently released annual user survey by Web survey company E-Space.

**BEST INNOVATOR OF THE YEAR** – award given to Sandvik, Czech Republic, a recognition of the company's way of working with innovation. The organization behind the award is the global consulting company A.T. Kearney.

## TIME AND ENERGY-EFFICIENT SPARE PARTS

**KEEPING CONE CRUSHERS** running with as short and as few maintenance stops as possible is critical for Sandvik's customers. Sandvik has launched three new spare parts aimed at enhancing the performance of the crushers. An 80 percent quicker change time compared with competitors means more efficient use. The new design also requires no heating or grinding, making the changing process faster and safer.



## LAPTOP DONATIONS TO VOLUNTEER TEAM

Sandvik recently donated laptops to the Northeast Counseling Services Assertive Community Treatment Team (ACT), in Pennsylvania, in the United States. The ACT team is a voluntary community-based program that provides comprehensive mental health, rehabilitation and support services to people aged 18 or older in need of such services. Now there will be enough laptop computers to be used in the team's office and the nurses in the field.



Bauma  
China 2014  
欢迎你

比例模型玩具网  
恭祝展会成功  
scaletoys.com

## NEW SCREEN PROVIDES VERSATILITY AND PERFORMANCE

A new circular stroke inclined screen, the SK2462, was globally launched at the Bauma China trade fair recently. Part of a new range from Sandvik Construction, it is able to operate effectively in both wet and dry operating conditions and deal efficiently with most applications providing customers with leading levels of versatility, performance and flexibility.

## Sandvik is again included in the Sustainability Yearbook, which lists the world's most sustainable companies in each industry.

This is the sixth time Sandvik has been included in the Yearbook, one of only ten Swedish companies to make the list. The Sustainability Yearbook has been published every year since 2004.

# FOCUS

A large industrial facility, likely a steel mill, with complex machinery, walkways, and a glowing furnace on the right side. The scene is dimly lit with blue and white overhead lights, and a bright yellow glow emanates from a furnace on the right. The foreground features a large, shallow, circular metal basin. The background shows multiple levels of walkways and structural beams.



# CLIMATE-SMART MANUFACTURING

The majority of scientists agree that human behavior is the major driving force behind climate change. Therefore, the task to change environmental impact lies in the hands of humans and companies. TEXT: ÅSA BACKMAN

Global warming is one of the world's biggest challenges. In order to meet climate goals, the world must substantially reduce carbon emissions. How can energy-intensive companies such as Sandvik contribute?

**MODERN TECHNOLOGY HELPS US** to build more climate-smart plants and offices, as well as reduce our house hold emissions, but the goal is also to help customers become more energy-efficient.

"By offering highly productive products that provide high energy efficiency, we can help our customers reduce their impact on the environment," says Christina Båge-Friborg, Head of Sandvik Sustainable Business.

Stig Jansson, Technical Manager at the brand new climate-smart Sandvik Coromant center in Sandviken, Sweden, agrees. He shows one of the center's new machines, which is much smaller than some of the others.

"This is one example where we've developed machining methods that require less energy," Jansson says. "With the right tools and methods, we can help our customers produce their components on a smaller machine with significantly lower impact and still reach the same result as with a large machine."

One area where Sandvik Machining Solutions have been in the forefront for many years is the recycling of solid carbide tools. During 2014, Sandvik Coromant recycled 98 percent of sold weight, and actually exceeded 100 percent during Q4 thanks to the fact that they accept all brands in their recycling bins.

"Knowing that it requires 70 percent less energy to produce tools from recycled solid carbide than making them from new raw material, it's an obvious thing to do," he says.

**SANDVIK MATERIALS TECHNOLOGY** also focuses on energy-efficient products and services such as energy-efficient heating cassettes for solar panels and corrosion-resistant stainless steel plates for fuel cells.

Furthermore, Sandvik Materials Technology has several internal stories to tell. One example is the collaboration with the local energy company in Västerås, Sweden. Through a new technique, the energy company helps the Sandvik unit in Hallsta- →



During 2014, Sandvik recycled 98 percent of its solid carbide tools, and actually exceeded 100 percent during Q4 thanks to the fact that they accept all brands in their recycling bins.



hammar, Sweden, recycle waste energy, which leads to yearly carbon dioxide savings of approximately 1,400 tons.

“The best kilowatt-hours are the ones we are not using,” says Nicklas Nilsson, Head of Product Area Strip, Wire and Heating Technology, Sandvik Materials Technology. “Walking or riding a bike instead of taking the car, turning the light off when you’re not in the room and other things that we can easily do – it all starts with you and me.”

**THE MINING INDUSTRY IS EXTREMELY ENERGY-INTENSIVE** and accounts for about 5 percent of the world’s consumption of electrical energy. To help mining companies reduce their emissions, Sandvik Mining has designed lightweight trucks and loaders with an intelligent powertrain design, powered by stage IV/tier 4-compliant clean engines that transfer all power to the movement of the truck. This means a lower impact on the environment and at the same time the lowest cost per ton for customers.

Australian mining company Mincor has invested in four new trucks, Sandvik TH551, equipped with an onboard weighing system. The investment allows the company to reduce the number of trucks by about half.

“There is a definite productivity benefit and therefore a cost improvement due to running fewer units to do the same job,” says Brett Fowler, General Manager of Operations at Mincor Kambalda.

Sandvik’s goal is to be one of the most sustainable companies in the industry. To succeed, every little step from each and everyone counts. ■



Follow us in social media and read more at [sandvik.com/sandvikstories](http://sandvik.com/sandvikstories)

# WELCOME TO THE JUNGLE

Nothing is as efficient as nature. That is why German automation company Festo has stepped into the wild to apply biological principles to the world of engineering.

**WHY REINVENT THE WHEEL**, when many solutions to traditional engineering challenges are already out there and are free? German company Festo has a goal to provide maximum productivity and competitiveness for its customers in factory and process automation.

In the company's Bionic Learning Network, a research network that links Festo to renowned universities, institutes, development companies and private inventors, it turned to the principles of nature to gain inspiration for technical applications and industrial practice. Animals perform such tasks as gripping, moving, controlling and measuring – tasks found in automation – instinctively and easily. Thus they may show humans how to achieve maximum efficiency with minimum energy consumption in a wide variety of ways.

The company has studied elephants' trunks in order to construct a flexible

gripper arm and has looked at jellyfish to visualize the communication structures and real-time diagnostics of autonomic subsystems in water. In 2013 Festo used the motion of ocean waves to create a pneumatic conveyor belt that can both sort and transport objects.

The company's latest project is a "bionic kangaroo," inspired by its Australian real-life counterpart. The mechanism is a complex combination of pneumatic and electrical drive technology that mimics the animal's unique way of moving. Like its natural model, it can recover energy when jumping, store the energy from the landing phase and retrieve it efficiently on the next jump.

Since 2006, Festo has realized more than 40 projects in the program, using inspiration from such members of the animal kingdom as barracudas, penguins, stingrays and dragonflies. ■



The disaster at Fukushima triggered an array of initiatives to lower Japan's energy consumption. Sandvik launched an energy-saving program aimed at reducing customers' energy consumption by 15 percent.





# ENERGY SAVINGS IN THE WAKE OF A TSUNAMI

Sandvik is providing technological solutions to Japanese companies seeking to reduce their energy consumption in response to the new reality of higher electricity prices since the Fukushima nuclear disaster.

**THE TSUNAMI** that knocked out the Fukushima Daiichi nuclear power plant in Japan in 2011 permanently changed public attitudes towards nuclear energy. The country is still heavily dependent on some 50 reactors that provided around 30 percent of its electricity, but energy policy is moving Japan towards alternative sources. At present, 84 percent of Japan's energy comes from expensive imports, giving industry no choice but to seek less energy-intensive procedures.

The laws of material science fix the total amount of energy necessary to carry out a task. While there are no magic tools that eliminate power consumption, through process optimization we can reduce machine load and machining time to reduce the impact of expensive electricity.

"Japanese industry is

generally energy-efficient, but more can be done," says Shinichi Takamiya, Product and Application Manager at Sandvik Coromant Japan.

The disaster at Fukushima triggered an array of initiatives to lower Japan's energy consumption and dependence on nuclear power. Sandvik responded by launching an energy-saving program aimed at reducing customers' energy consumption by 15 percent. The program promotes a variety of measures, including dry cutting, quick-change tool modular systems and lead-time reduction.

"Japanese customers, especially those with long production lines, have responded enthusiastically by joining the program," Takamiya says.

In a typical case, Sandvik helped a Japanese maker of airplane parts reduce energy

consumption in machining. The solution involved replacing two machines with one multitasking machine equipped with our tools. This resulted in higher efficiency and time saved, while energy consumption fell by 43 percent.

**JAPANESE COMPANIES** have long adhered to continuous improvement programmes. In the past, energy was taken for granted, whereas today, reduction of energy consumption is a goal in itself, according to Takamiya.

Sandvik systematically documents the energy efficiency of its application methods and tools by collecting data. For example, CoroMill™ 490, a shoulder and face-milling cutter exercises low cutting forces and can reduce electricity consumption by 17 percent compared with an average reference cutter. CoroMill™ 490, featuring a combination of the tool and high-pressure coolant, decreases the time spent on managing chips. An operation machining 200 car parts per day, for example, can double production.

Sandvik initially promoted the program in the disaster-affected regions of Eastern Japan, but the market response since justified expansion to cover the whole country.

"We are learning things that will benefit customers around the world," Takamiya says. ■



Top image: Sonali Mulay, General Manager, Technology Management, Angala Srinivasan, Sandvik Site Director, and Medha Takawale, HR.

# CHILD'S PLAY CREATES JOBS

At Sandvik's manufacturing facility in Pune, the day care center has opened up big opportunities to attract employees with diverse perspectives. One way of walking the talk when it comes to diversity and inclusion.

TEXT: R.F. MAMOOWALA PHOTO: ASHESH SHAH

## **ANSHUL IS BARELY 3 YEARS OLD,**

but when he wakes up every morning he says, "I have to go to Sandvik."

No, the Sandvik headquarters in Pune, India, does of course not employ children. But ever since his mother, Sonali Mulay, General Manager, Technology Management, returned from maternity leave, Anshul has been accompanying her to the spacious and cheerful day care center, set up in 2010.

"He gets milk and meals every two hours, participates in activities such as storytelling and has developed good habits," Mulay says. "Unlike his sister, who I had to feed till she was 3, Anshul has fed himself since he was 1, which is amazing."

In the industry in India, Mulay stands out. In her team of 75, only two are women. When Angala Srinivasan, Sandvik's Site Director, SMS Operations, began looking for a mechanical engineer with 15 years' experience and

said that he wanted to hire a woman, in line with the company's policy of diversity and equal opportunity, he was told that such a person didn't exist. Still he persisted and found Mulay, whose qualifications were a perfect fit. The hiring process was almost complete when Mulay found she was expecting a child.

They now faced the challenge that, under Indian law, Sandvik gave 12 weeks of maternity leave, but the company day care center only took in babies who were at least 6 months old. But Srini, who was part of the policy-making committee, pushed for changes, saying, "If we really want to encourage women to join the organization, we have to try harder."

The result was 20 weeks of maternity leave and a change in the entrance age for the day care center to 4 months. Mulay became the first employee to utilize the privilege.

Initially the day care center was open →



only to help female employees, but now it is open to any employee with a child until that child is 6 years old. Now 30 Sandvik employees use its services, which have been outsourced to Purple Patch, a trusted brand in Pune.

Srini is keen to encourage other women to apply for positions at the company. In March 2014, when Medha Takawale, in the final round of interviews for a post as HR Business Partner, also discovered she was expecting a child, Srini reassured her about the company policy of 20 weeks of maternity leave, medical insurance and of course the day care center. These factors relieved most of her tensions, she says.

"They have a canteen too, so I don't have to cook early in the day," she says.

**TAKAWALE RETURNED** to work in January 2015, happy that her son is well taken care of. "The center calls me when I'm needed for my baby," she says.

Championing diversity in India has not been easy. It wasn't until 2003 that Sandvik hired its first female manager,

an HR executive, to join the all-male team of 14 managers. India doesn't have too many senior female mechanical engineers and it's a challenge to recruit women to non-traditional female jobs, explains Sandvik's Vaishali Surve, Associate VP, Compliance, who is also leading the diversity and inclusion portfolio for India.

Another drawback is old legislation prohibiting women from working on the shop floor in engineering industries after 7 p.m. But in an effort to bring in more women, Sandvik has employed 25 women in production and allied services for the day shift.

Surve says that a group that is diverse tend to be more committed, passionate and ethical. Sandvik India keeps pushing for diversity across gender (in Pune there are 108 women out of a total of 1,136 employees), regions and cultures, and the latest addition to its management team is a woman CFO.

A diverse organization where everyone is included, and which is built on its members differences, is able to meet the challenges and requirements of current and future customers. ■

# REPORT

Figures from the interim report

- Trends and tendencies
- Key figures and news
- CEO comment
- Interview

			-0,06	-0,14%
	17,12	17,19		
		42,14	+0,56	1,91%
	25,98	27,87	+0,17	3,52%
	22,73	21,18	+0,26	0,89%
	25,19	27,33	-1,14	-4,08%
	27,17	31,58	+13,53	3,32%
	96,73	96,51	+0,82	0,54%
	25,78	25,32	+0,41	1,62%
	27,19	29,81	+0,22	

## FIGURES from the Interim Report Q4 2014

### INVOICED SALES BY BUSINESS AREA

MSEK	Q4 2014	Q4 2013	Change %	Change %
Sandvik Machining Solutions	8,122	7,363	+10	+3
Sandvik Mining	7,039	7,334	-4	-9
Sandvik Materials Technology	3,758	3,360	+12	+12
Sandvik Construction	2,169	2,174	-0	-7
Sandvik Venture	2,301	1,538	+50	-1
Group Activities	5	1		
Group Total	23,394	21,770	+7	-1

### OPERATING PROFIT BY BUSINESS AREA

MSEK	Q4 2014	Q4 2013	Change %
Sandvik Machining Solutions	1,622	1,084	+50
Sandvik Mining	644	-480	N/A
Sandvik Materials Technology	330	350	-6
Sandvik Construction	4	-223	N/A
Sandvik Venture	335	309	+8
Group activities	-312	-450	
Group total <sup>1)</sup>	2,623	590	+345

### OPERATING MARGIN BY BUSINESS AREA

% OF INVOICING	Q4 2014	Q4 2013
Sandvik Machining Solutions	20.0	14.7
Sandvik Mining	9.2	-6.5
Sandvik Materials Technology	8.8	10.4
Sandvik Construction	0.2	-10.2
Sandvik Venture	14.6	20.1
Group total	11.2	2.7

## INVOICED SALES Business areas share of Group's total invoiced sales

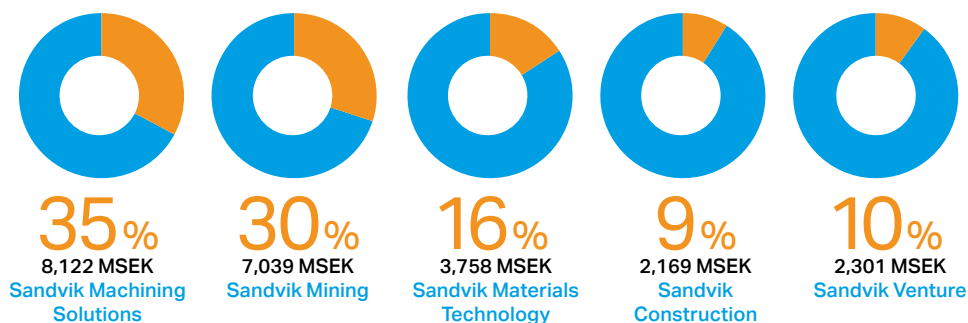

# TRENDS AND TENDENCIES

## MATS BACKMAN, CFO

### HOW WOULD YOU DESCRIBE SANDVIK'S FINANCIAL POSITION TODAY?

I feel we are well positioned and believe we will grow at a faster pace than the average market growth in the coming years. We have strong market positions within sectors such as mining, metal cutting and energy. That, combined with our strong customer offering gives us every possibility to capture market share. That said, competition is fierce and we need to make sure we excel in product development and customer focused innovation. As an example we are introducing more than 15,000 new products this year within Sandvik Machining Solutions. Cash generation and net working capital will continue to be in focus since cash is a prerequisite for investments and growth. We are making good progress in this area but we still have work to do before we land net working capital on a low and sustainable level.

### WHAT, IN YOUR OPINION, ARE THE MOST SIGNIFICANT MARKET TRENDS RIGHT NOW?

The low oil price is affecting demand in the oil and gas sector. Within the mining sector,

the demand remains at a low level. On the other hand, we see an overall positive development in North America, strong demand in the aerospace sector and also some positive effects from the low oil price on demand within various parts of our business. From a long-term perspective, we believe in our strategy to further strengthen our position within the energy segment, albeit near term demand may be hampered by the low and volatile oil price.

### CAN YOU TELL US SOMETHING ABOUT ANY CURRENT OPERATIONAL EFFICIENCY ACTIVITIES?

For us to stay competitive, a competitive cost position and efficient operations are always in focus. We are currently in the middle of implementing our Supply Chain Optimization program, reducing our number of production units by about 25. We are also implementing initiatives to drive quality and to capture economies of scale within our support functions such as IT, Finance and HR. ■



## INVOICED SALES BY MARKET AREA Share of group invoicing

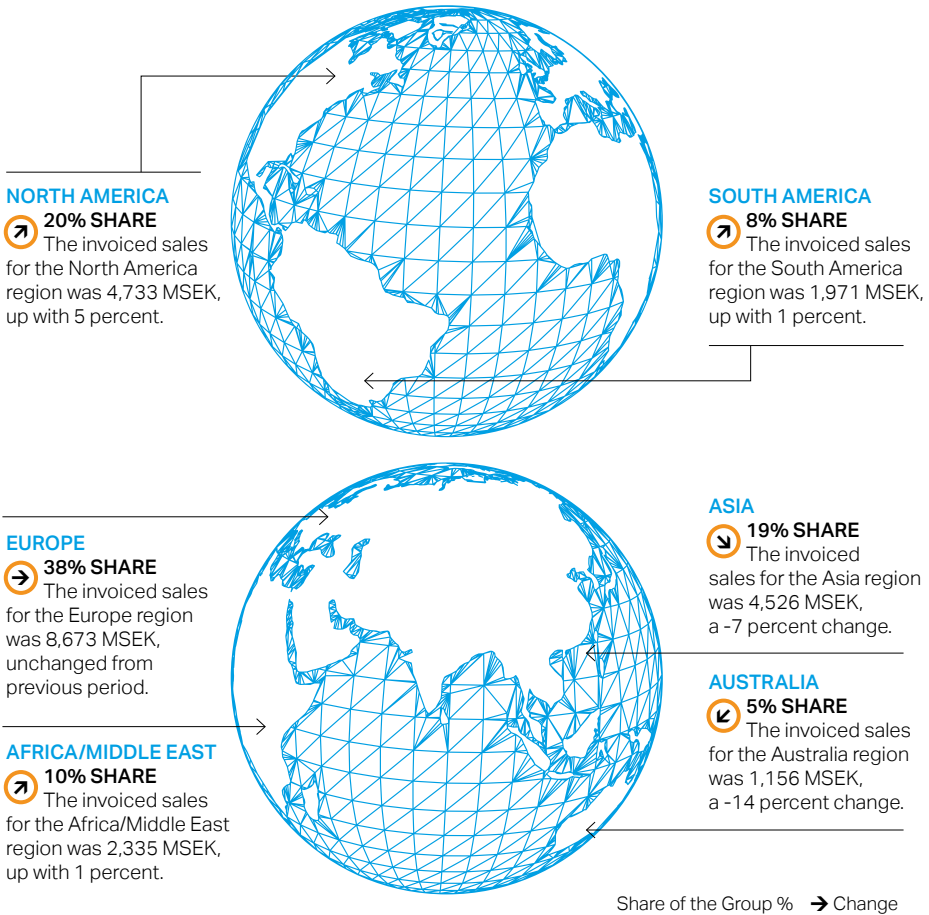

## INVOICED SALES by segment

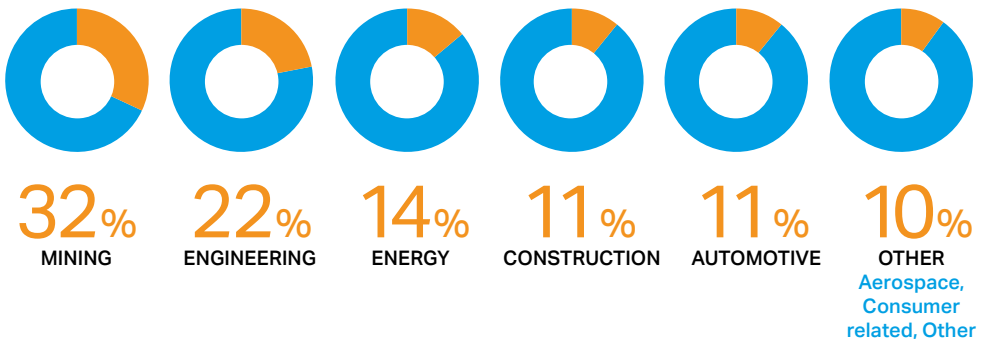



## CEO COMMENT TO Q4:

**“Looking back at the fourth quarter in isolation, we noted a mixed demand pattern.** The underlying business activity remained largely unchanged compared with the preceding quarter, except for a slight increase in the level of caution being exercised by customers in the energy segment. In the long term, we believe in the viability of our strategy to further grow our position in the energy segment, however short-term demand is likely to be hampered by a low and volatile oil price.”

Read more on [sandvik.com/investors](http://sandvik.com/investors)

## LESS INJURIES AND HIGHER PRODUCTIVITY

In 2014, the lost time injury frequency rate (LTIFR) was reduced in all Sandvik's business areas.

The Group's LTIFR has improved 43 percent over the course of only three years, and a 22 percent improvement compared with the preceding year.

A lost-time injury is defined as an occurrence that resulted in a fatality, permanent disability or time lost from work of one day/shift or more.

Lost-time injury frequency rates are the number of lost-time injuries within a given accounting period relative to the total number of hours worked in the same accounting period.

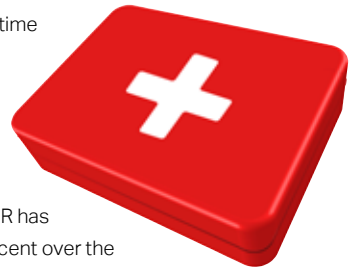

## NEW PRODUCT RELEASE

Sandvik will launch its new top hammer drill rig at the Aggregates Academy & Expo 2015 in Baltimore, USA, in March. Sandvik Dino™ DC400Ri top hammer drill rig combines the largest coverage area in its class with excellent mobility and agility, and is suited for any type of construction site. Dino™ DC400Ri is engineered from the start to hold all the best features in one - drilling performance with high hole quality, easy maintenance and excellent maneuverability – combined with a new design.



# 1.21

## Earnings per share, SEK

Order intake **21,286 MSEK** / Invoiced sales **23,394 MSEK** / Operating profit **2,623 MSEK** / Profit after financial items **2,121 MSEK** / Profit for the period **1,504 MSEK** / Cash flow from operations **+4,104 MSEK**

## THE KEYS TO GROWTH

When the market is slow it is even more important to build strong long-term relationships, says Joanne Cooke, VP Finance at Sandvik Construction.

### HOW WOULD YOU DESCRIBE THE MARKET AND THE GROWTH OPPORTUNITIES FOR SANDVIK CONSTRUCTION IN RECENT YEARS?

Due to the financial crisis, growth has been quite flat in recent years. The majority of our business comes from infrastructure spending, where there have been budget cuts for most countries. That said, I still think we can find pockets of growth in these times.

### WHERE DO YOU FIND THESE POCKETS OF GROWTH?

When our customers are not buying new equipment, it is even more important to support the equipment they do have. That makes aftermarket – our service offering – crucial. We also see opportunities in

certain regions, particularly North America. In Asia, especially China, we are able to maximize the potential of our offering for both mid-market and premium segments.

### WHAT ARE THE BIGGEST CHALLENGES FOR SANDVIK CONSTRUCTION TO CREATE GROWTH?

When shifting more toward the aftermarket we are dealing with a lot of competition, which increases the price pressure. However, we feel confident that the quality we can offer, in both service and product offering, is at a much higher standard than many of our competitors. We focus on leveraging our installed base of equipment through an improved choice of service

contracts that will result in aftermarket growth. It comes down to building long-term relationships and, for us internally, sharing knowledge across product areas and regions. Later in 2015 and in 2016 we predict there will be more spending on infrastructure, and the market for new equipment will grow. In addition, the launch of any new equipment opens up new opportunities for aftermarket. If we are top of the class in that area we are stable, as we are in a good position for when investment growth returns. ■

Joanne Cooke, has been appointed President for Sandvik Construction Product Area Equipment.

---

"WE FEEL CONFIDENT THAT THE QUALITY WE CAN OFFER, IN BOTH SERVICE AND PRODUCT OFFERING, IS AT A MUCH HIGHER STANDARD THAN MANY OF OUR COMPETITORS."

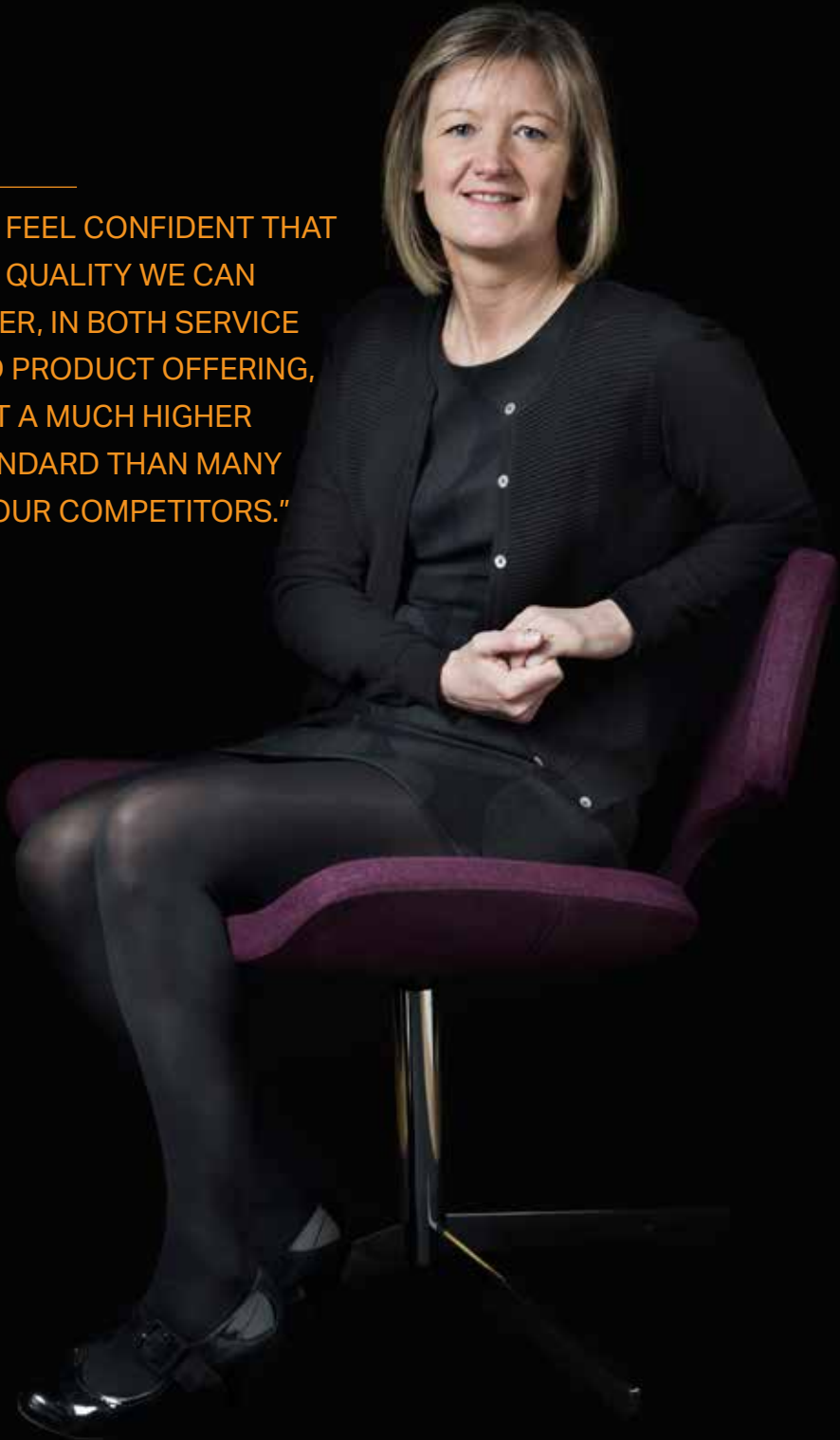

PHOTO: SAMMY STEEN

# MEET THE BIONIC MAN

When successful US snowmobile racer “Monster” Mike Schultz lost his leg, he knew his life would be different. But not how different. Through innovative thinking and homemade engineering skills, he came up with a pioneering solution that got him back in the saddle again.

TEXT: KIP HANSSON PHOTO: PER-ANDERS PETTERSSON

**US SNOWMOBILE RACER** Mike Schultz began snocrossing professionally in 1998, and his career soon took off. “I worked my way up,” he says. “Going into the 2008 season I was in my prime, one of the top five guys in the world on a snowmobile. I was living my dream.” But during the second national round in Michigan, disaster struck.

“I had a horrible start and coming down a hill, the sled got a little squirrely and bucked me off,” he remembers.

He’d crashed like that a hundred times before and walked away, he says, but this time was different.

“When I hit the ground, my knee hyper-extended,” he says. “It just blew apart.”

Things quickly went from bad to worse. “Three days after the accident I’d gone through 47 units of blood, and my kidneys were shutting down,” Schultz says. “The doctors woke me up to tell me they were amputating my leg.”

Schultz spent 13 days in hospital and after five weeks he tried his first pros-

thetic leg. He was able to walk, but he considered his racing days over. Then he heard of the Adaptive X-Games Supercross where disabled athletes could compete. Now the hunt for a sports-capable prosthetic began.

“Everyone’s always known me as the guy who tinkered in the shop,” says Schultz. “I had lots of friends from the racing community, and they started joking around right away about me building my own knee. That was the catalyst for me.”

Using a sketchpad and cardboard cutouts, Schultz began designing something completely new. Despite a lack of engineering skills, he says, “I think mechanically, and I’ve always been a problem solver. The knee had to absorb shock. It had to bend at least 135 degrees. And it had to be adjustable for different sporting activities.”

Schultz wanted to use a mountainbike →





Back in the saddle, after inventing his own prosthetic, designed for sports, Mike Schultz was able to compete again.

shock, of the brand FOX, as the guts of his new prosthesis. Within a month, he had a good working drawing, which he brought to a shop in his home state of Minnesota. "They gave me a quick rundown on how to use the mill and the lathe and turned me loose," he says. "I machined the first knee myself. I remember the feeling when I pulled the parts out of the mill, bolted it all together and stuck it on my leg. I got on a dirt bike that same day, grinning from ear to ear. Right then I knew I'd be able to do some pretty cool stuff with this."

Less than five months after the accident, Schultz and his new knee raced motocross at Michigan's Extremity Games, qualifying him for the 2009 ESPN Summer X Games Supercross. Since then, Schultz has made five revisions to the original design and now markets his product under the brand name Moto Knee. He's also started a new company, Biodapt Inc., with the goal of being the leading edge in high-activity prosthetic equipment.

One grateful customer is Michelle Salt, who lost her leg in a motorcycle accident in 2011. Physicians told her she wouldn't snowboard again, but that didn't matter to Salt. "One of the first things I thought of was how to get back on the board. So when I heard about this guy making prosthetic knees for athletes, I gave him a call. I'm actually the first female to use the Moto Knee." She went from being unable even to stand up to qualifying for the Canadian para-snowboard team in less than a year.

Another Moto Knee wearer is adap-

tive athlete Geoff Turner, who suffered a traumatic amputation in 1990 after a motorcycle accident. Turner's physicians told him not to expect too much. "They just looked at me grimly and shook their heads." Since then, Turner has proved his doctors wrong by running (and winning) several marathons and half-marathons. He recently qualified for the US bobsled team and is looking at the triathlon in the 2016 Paralympics. ■

**JOANN MITCHELL, SENIOR PROJECT LEADER, SANDVIK US:**

**WHY DOES SANDVIK SPONSOR THE AMERICAN WEB SHOW EDGE FACTOR, A SHOW MIKE SCHULTZ IS INVOLVED IN, ABOUT MODERN MANUFACTURING AND INNOVATION?**

It's part of our responsibility to help our customers be successful in their endeavors, as well as to help people outside the industry understand the value of metalcutting in modern life.

**COULD A SHOW LIKE EDGE FACTOR BE AN EYE OPENER FOR STUDENTS CHOOSING THEIR CAREER PATH?**

Yes, because Edge Factor shows the excitement of building solutions to help people. The show demonstrates the possibilities in modern manufacturing – the innovation needed in real customer situations, in real workshops, making products all of us find valuable. For many people, this is the first time they have seen modern machining and can see the creative technology involved.



Mike Schultz built his own prosthetic knee using a sketchpad and cardboard cutouts. Machining the parts and welding, he learned along the way. His Moto Knee has helped others in the same situation.



## **THE OBJECT** | The insert

---

**An insert, used in the manufacturing industry to cut metal, is mainly made out of various combinations of tungsten carbide and cobalt.** Tungsten is a finite resource, so recycling is important. Only a small part of the insert is actually worn away during its working life; about 95% can be recycled.